



RIVAL 600 SERIES WIRE FEED UNIT RIVAL RX-2 & RX-4 TWO and FOUR ROLL UNITS



OPERATION MANUAL

SPECIFICATION

		RX 2-B	RX 2	RX 4
Drive System		2 Roll direct drive	2 Roll direct drive	4 Roll geared drive
Speed Range		1 – 25 m/min.	1 – 25 m/min.	1 – 25 m/min.
Supply Voltage		24v or 42v a.c	24v or 42v a.c	24v or 42v a.c
Motor Power		40W	90W	90W
Wire Sizes				
	Hard	0.6 – 1.0 mm	0.6 – 1.2 mm	0.8 – 1.6 mm
	Soft	0.8 – 1.0 mm	0.8 – 1.6 mm	0.8 – 1.6 mm
	Cored	N/A	1.0 – 1.2 mm	1.0 – 1.6 mm
Dimensions (Approx.)				
	Height	265 mm	265 mm	265 mm
	Width	320 mm	320 mm	320 mm
	Length	600 mm	600 mm	600 mm
Weight (Approx.)		15.0 Kg.	15.5 kg	15.5 kg

N.B. Claimed capacities and ratings will depend upon correct installation, use, application, maintenance, and service.

WARNING

This Rx series feed unit has been designed & constructed using the highest quality materials available to ensure long & trouble free service. However, regular maintenance is an essential part of keeping this equipment working in a safe & reliable manner. Your attention is drawn to the maintenance instructions contained in this manual. Failure to follow these recommendations may invalidate any warranty.

RX-4 600 SERIES SPARE PARTS

CASE PARTS

DESCRIPTION	RX4 PART No.
Euro Assembly Complete	4020
EURO ASSEMBLY COMPONENTS	
Euro Body Connector	4031
Brass Adaptor Tube	4007
Current Conductor Clamp	4030
Wire Outlet Guide Tube	4044
Insulating Flange	4032
OTHER COMPONENTS	
Main Control PCB 24 volt	RE271B-24
Main Control PCB 42 volt	RE271B-42
Gas Solenoid Valve 24 volt	4057
Gas Solenoid Valve 42volt	4016
Wire Speed Control Potentiometer	4000
Control Knob For Above	4001
Wire Inch / Gas Purge Switch	4003
Torch Latch Switch	4002
20 Way PCB Connector	4011
Fuse holder x 2	4004
Fuse 1A 20mm	4066
Fuse 10A 20mm	4065
Wire hub assembly	4008
Carrying Handle	4059

DRIVE PARTS

RIVAL RX-4 Drive Mechanism

	DESCRIPTION	PART No
1	FEED BLOCK COMPLETE	42037
2	PRESS ARM AXLE	20001
3	SCREW	24103
4	PRESS ARM REAR	21502
F5	PRESS ARM FRONT	21503
6	PRESS ROLL AXLE	20005
7	BACK SPACER	20009
8	PRESS ROLL	38306
9	FRONT SPACER	20009
10	PRESS ARM SPRING REAR	24402
11	PRESS ARM SPRING FRONT	24403
12	PRESS ARM SPRING	24404
13	PRESS CONTROL COMPLETE	42000
14	PIN	24252
15	DRIVE ROLL AXLE	20019
16	PRESS CONTROL COMPLETE	42000
17	FEED ROLL DRIVEN GEAR	42016
18	SEE BELOW	
19	FEED ROLL SCREW	20025
20	INTERMEDIATE GUIDE	42001&2
21	SCREW	24100
22	INLET GUIDE	20021&2
23	THREAD PLUG M6	24251
24	COVER PLATE	23500
25	MAIN DRIVE GEAR	21000
26	DRIVE GEAR SCREW	20026
27	INSULATION STRIP	22001
28	INSULATOR	21506
29	PRESS ADJUSTER TOP	21505
30	PRESS ADJUSTER BODY	21504
31	PRESS ADJUSTER SHAFT	20030
18	Feed roll 1.2 - 1.6 HW	5116
	Feed roll 0.8 - 1.0 HW	5130
	Feed roll 1.0 - 1.2 HW	5131
	Feed roll 1.2 - 1.6 TUB	5133
	Feed roll 1.6 - 2.4 TUB	5132
	Feed roll 1.0 - 1.2 ALUM	5134
	Feed roll 1.2 - 1.6 ALUM	5135
	Feed Motor (Not shown)	24V 90W 100701 42V 90W 100705

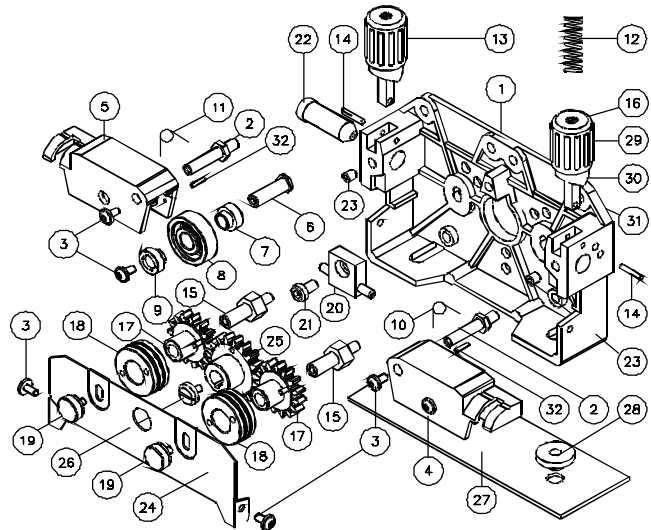
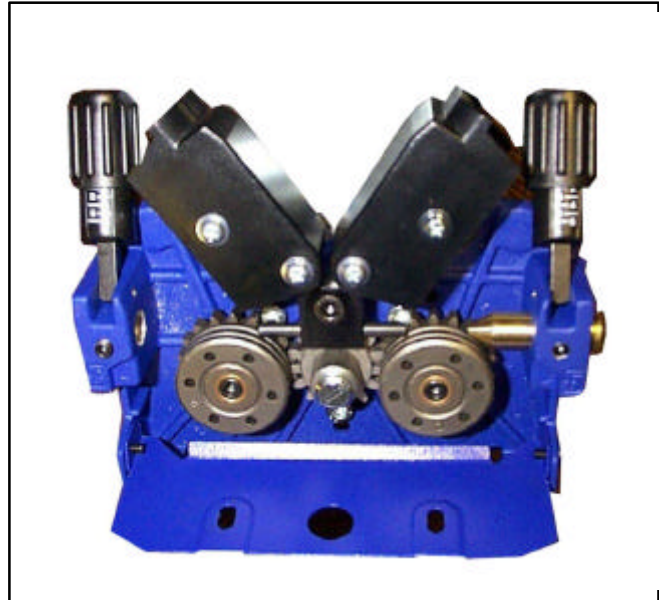

**RIVAL SPARES AND ASSISTANCE
0800 917 0816**

RX-2 600 SERIES SPARE PARTS

CASE PARTS

DESCRIPTION	RX2 PART No.
Euro Assembly Complete	4019
EURO ASSEMBLY COMPONENTS	
Euro Body Connector	4031
Brass Adaptor Tube	4006
Current Conductor Clamp	4030
Wire Outlet Guide Tube	4043
Insulating Flange	4032
OTHER COMPONENTS	
Main Control PCB 24 volt	RE271B-24
Main Control PCB 42 volt	RE271B-42
Gas Solenoid Valve 24 volt	4057
Gas Solenoid Valve 42volt	4016
Wire Speed Control Potentiometer	4000
Control Knob For Above	4001
Wire Inch / Gas Purge Switch	4003
Torch Latch Switch	4002
20 Way PCB Connector	4011
Fuse holder x 2	4004
Fuse 1A 20mm	4066
Fuse 10A 20mm	4065
Wire hub assembly	4008
Carrying Handle	4059

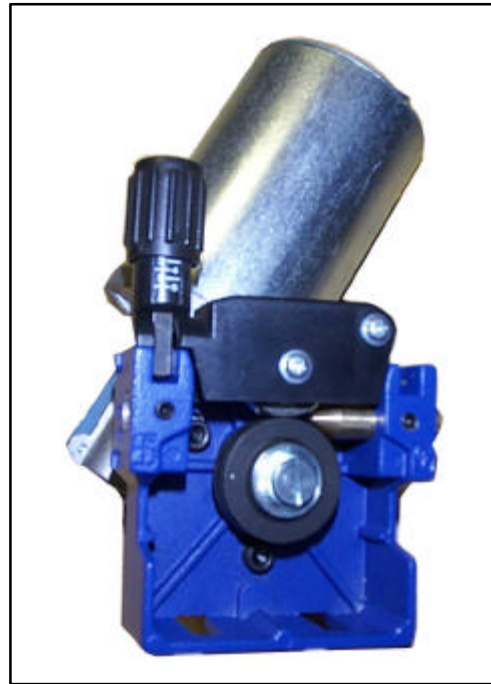

DRIVE PARTS

RIVAL RX-2 Drive Mechanism

	DESCRIPTION	PART No
1	FEED BLOCK COMPLETE	22037
2	PRESS ARM AXLE	20002
3	SCREW	24103
4	PRESS ARM	23007
5	AXLE, PRESS ARM	20028
6	SPACER, BACK	20010
7	PRESS ROLL	383763
8	SPACER, FRONT	20012
9	PRESS ARM SPRING	24404
10	PRESS ADJUSTER KNOB	21505
11	PRESS ADJUSTER SPRING	24401
12	PRESS ADJUSTER PIN	24252
13	INLET GUIDE	20022
14	SCREW (2)	24251
15	SEE BELOW	
16	FEED ROLL SCREW	20026
17	INSULATOR PLATE	22000
18	INSULATOR	21506
19	PRESS ARM KNOB	21505
20	PRESS ADJUSTER BODY	21504
21	PRESS ADJUST COMPLETE	42000
15	Feed roll 0.6 - 0.8 HW	5239
	Feed roll 0.8 - 1.0 HW	5129
	Feed roll 1.0 - 1.2 HW	5136
	Feed roll 0.8 - 1.0 ALUM	5132
	Feed roll 1.0 - 1.2 ALUM	5139
	Feed Motor	24V 90W 100701 42V 90W 100705

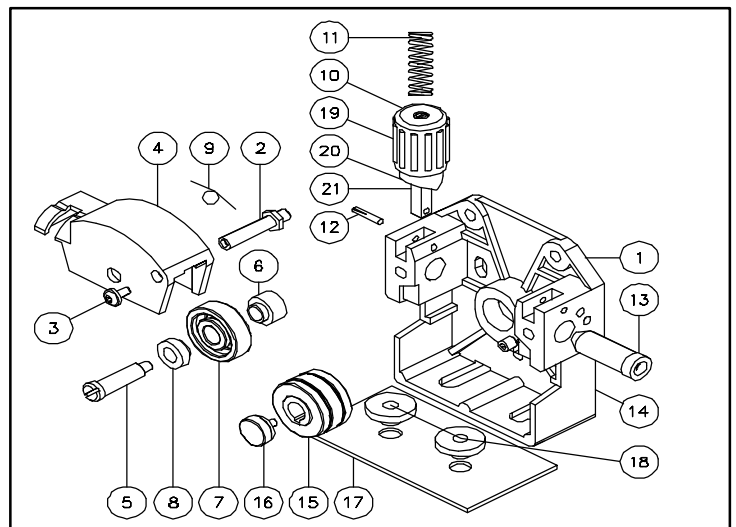

RIVAL SPARES AND ASSISTANCE
0800 917 0816